

TRF416

TAMIYA RACING FACTORY

CHASSIS KIT

1/10 SCALE R/C 4WD RACING CAR
TRF416 CHASSIS KIT

SETTING SHEET

Name	Date	Air Temp.	Humidity
Denicola	06.-07.03.2010	21°	35%
Track	Track Condition	Track Temp	
RC-Arena Indoor	high.grip	20°	

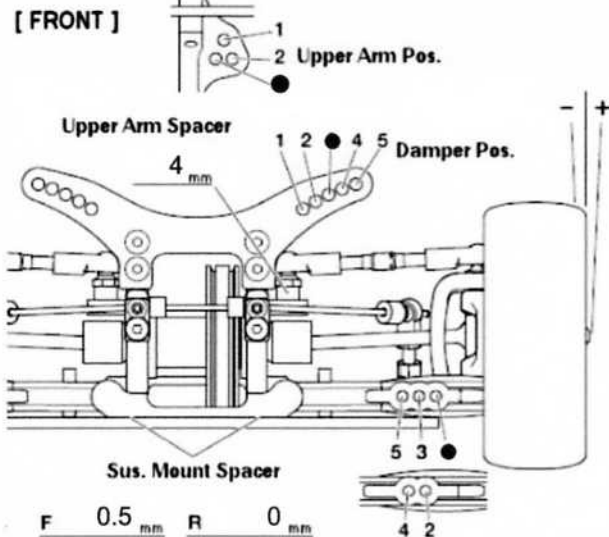

Caster Blocks	<input checked="" type="checkbox"/> 2 <input checked="" type="checkbox"/>
Camber	-1.5°
Ride Height	5.0 mm
Drop	*4 mm
Front Axle	<input checked="" type="checkbox"/> One-way <input type="checkbox"/> Diff <input type="checkbox"/> Spool
Roll bar	None <input type="checkbox"/> S <input checked="" type="checkbox"/> H
Wheel Spacer	0.5 mm



Shock Bushing	Red <small>Piece(s)</small>
Piston	3 <small>Holes</small>
Oil	LRP 50wt <small>Weight</small>
Spring	Tamiya Weiss
Shock Length	60 mm
Wheel Hex	<small>mm</small>
Rebound	<small>%</small>

Notes
*Dropp gemessen bei der Imbusschraube

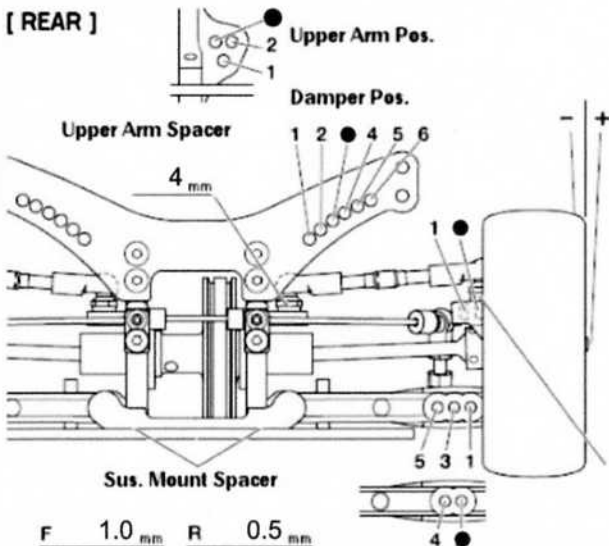

Rear Hub	0°
Camber	-1.5°
Ride Height	5.5 mm
Drop	4 mm
Roll bar	None <input type="checkbox"/> S <input checked="" type="checkbox"/> H
Wheel Spacer	1.5 mm
Upper Arm Spacer	3 mm



Shock Bushing	Red <small>Piece(s)</small>
Piston	3 <small>Holes</small>
Oil	LRP 50wt <small>Weight</small>
Spring	Tamiya Weiss
Shock Length	60 mm
Wheel Hex	<small>mm</small>
Rebound	<small>%</small>

Lipo leicht nach außen Montiert

Toe Angle	0.5°	F Sus. Mount F 1D R 1C	R Sus. Mount F 1XA R 1C
-----------	------	------------------------	-------------------------

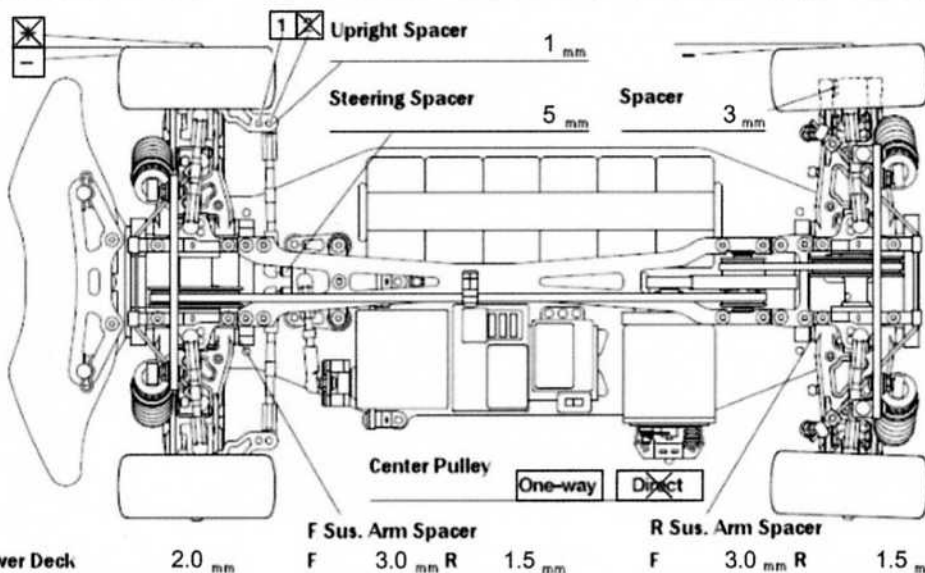

Motor	CS 13.5T
Spur	Pinion
	105 T 38 T
Battery	IP 5000
Body	Mazda 6 Speed leicht
Wing	Orginal
Tire	Sorex/GM 28
Wheel	
Insert	
Best Lap	