

# TRF416

TAMIYA RACING FACTORY

## CHASSIS KIT

1/10 SCALE R/C 4WD RACING CAR  
TRF416 CHASSIS KIT

### SETTING SHEET

Name \_\_\_\_\_ Date \_\_\_\_\_ Air Temp. \_\_\_\_\_ Humidity \_\_\_\_\_

Track \_\_\_\_\_ Track Condition \_\_\_\_\_ Track Temp \_\_\_\_\_

[ FRONT ]

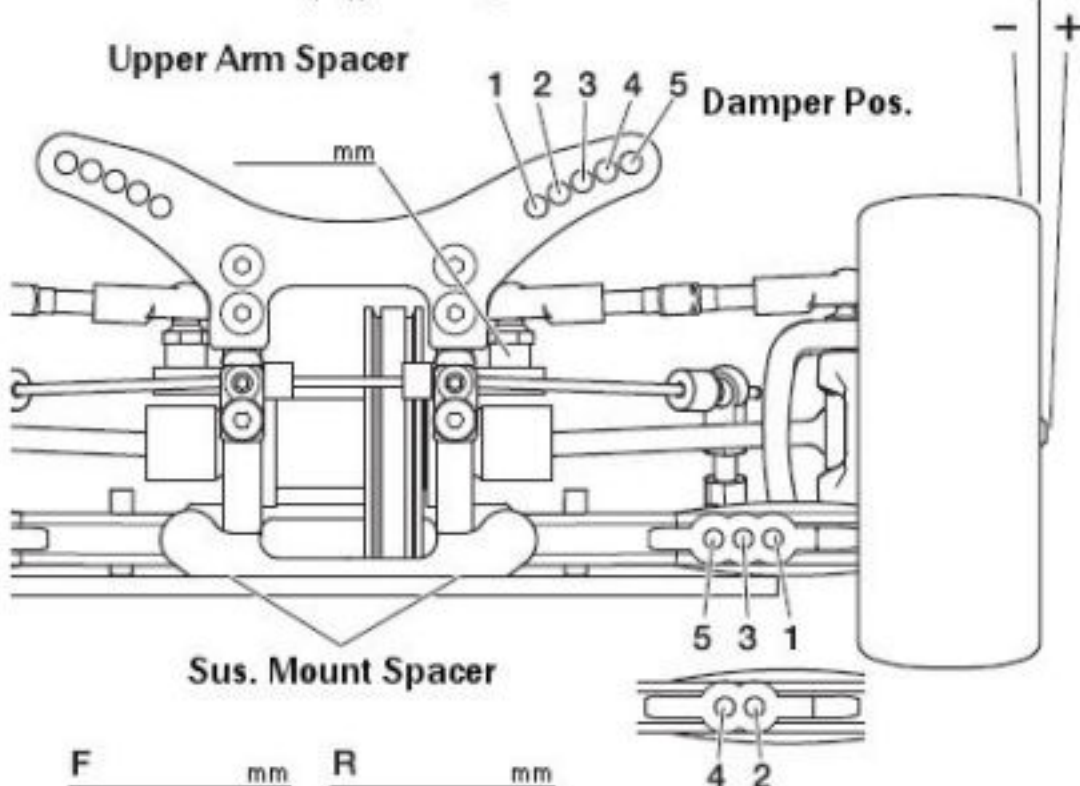
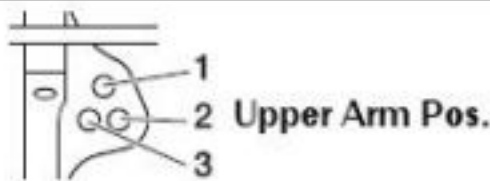

Caster Blocks \_\_\_\_\_  
Camber \_\_\_\_\_ 2° 4°  
Ride Height \_\_\_\_\_ mm  
Droop \_\_\_\_\_ mm  
Front Axle \_\_\_\_\_  
One-way Diff Spool  
Roll bar \_\_\_\_\_  
None S M H  
Wheel Spacer \_\_\_\_\_ mm  
Notes \_\_\_\_\_



Shock Bushing \_\_\_\_\_  
Piece(s) \_\_\_\_\_  
Piston \_\_\_\_\_  
Holes \_\_\_\_\_  
Oil \_\_\_\_\_  
Weight \_\_\_\_\_  
Spring \_\_\_\_\_  
Shock Length \_\_\_\_\_ mm  
Wheel Hex \_\_\_\_\_ mm  
Rebound \_\_\_\_\_ %

[ REAR ]

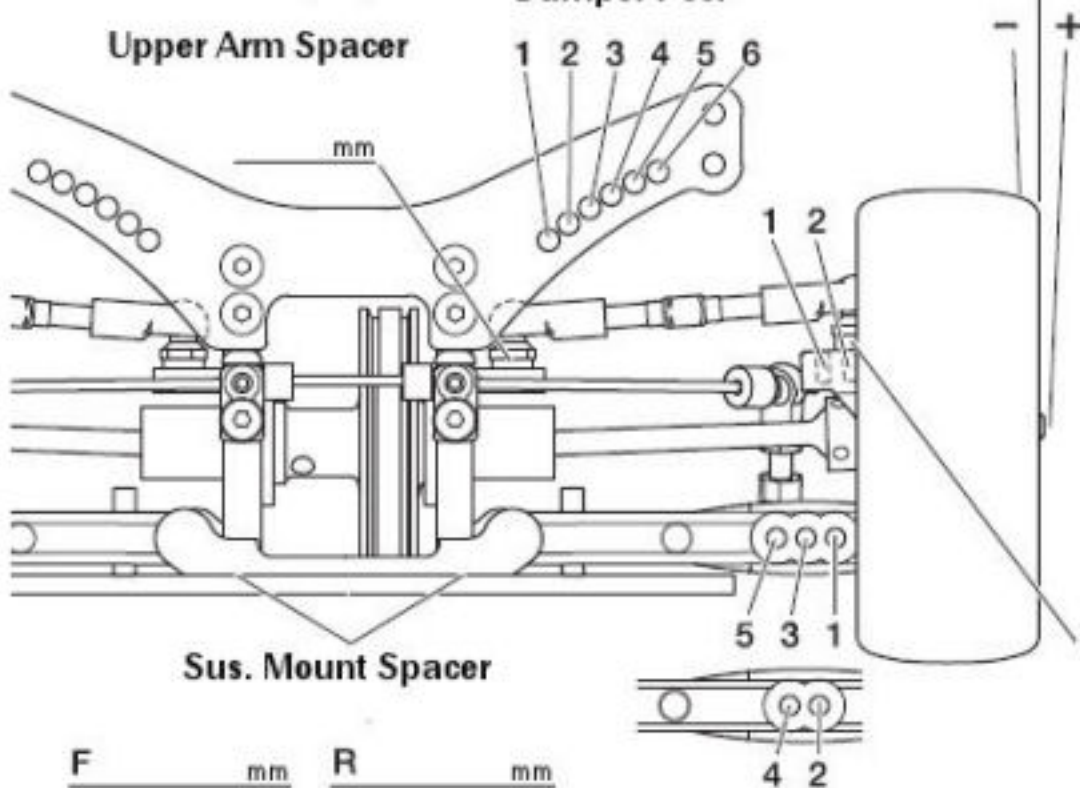
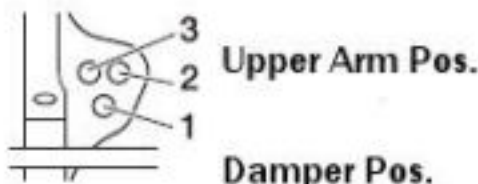

Rear Hub \_\_\_\_\_  
Camber \_\_\_\_\_  
Ride Height \_\_\_\_\_ mm  
Droop \_\_\_\_\_ mm  
Roll bar \_\_\_\_\_  
None S M H  
Wheel Spacer \_\_\_\_\_ mm  
Upper Arm Spacer \_\_\_\_\_ mm



Shock Bushing \_\_\_\_\_  
Piece(s) \_\_\_\_\_  
Piston \_\_\_\_\_  
Holes \_\_\_\_\_  
Oil \_\_\_\_\_  
Weight \_\_\_\_\_  
Spring \_\_\_\_\_  
Shock Length \_\_\_\_\_ mm  
Wheel Hex \_\_\_\_\_ mm  
Rebound \_\_\_\_\_ %

Toe Angle \_\_\_\_\_ ° F Sus. Mount F R R Sus. Mount F R

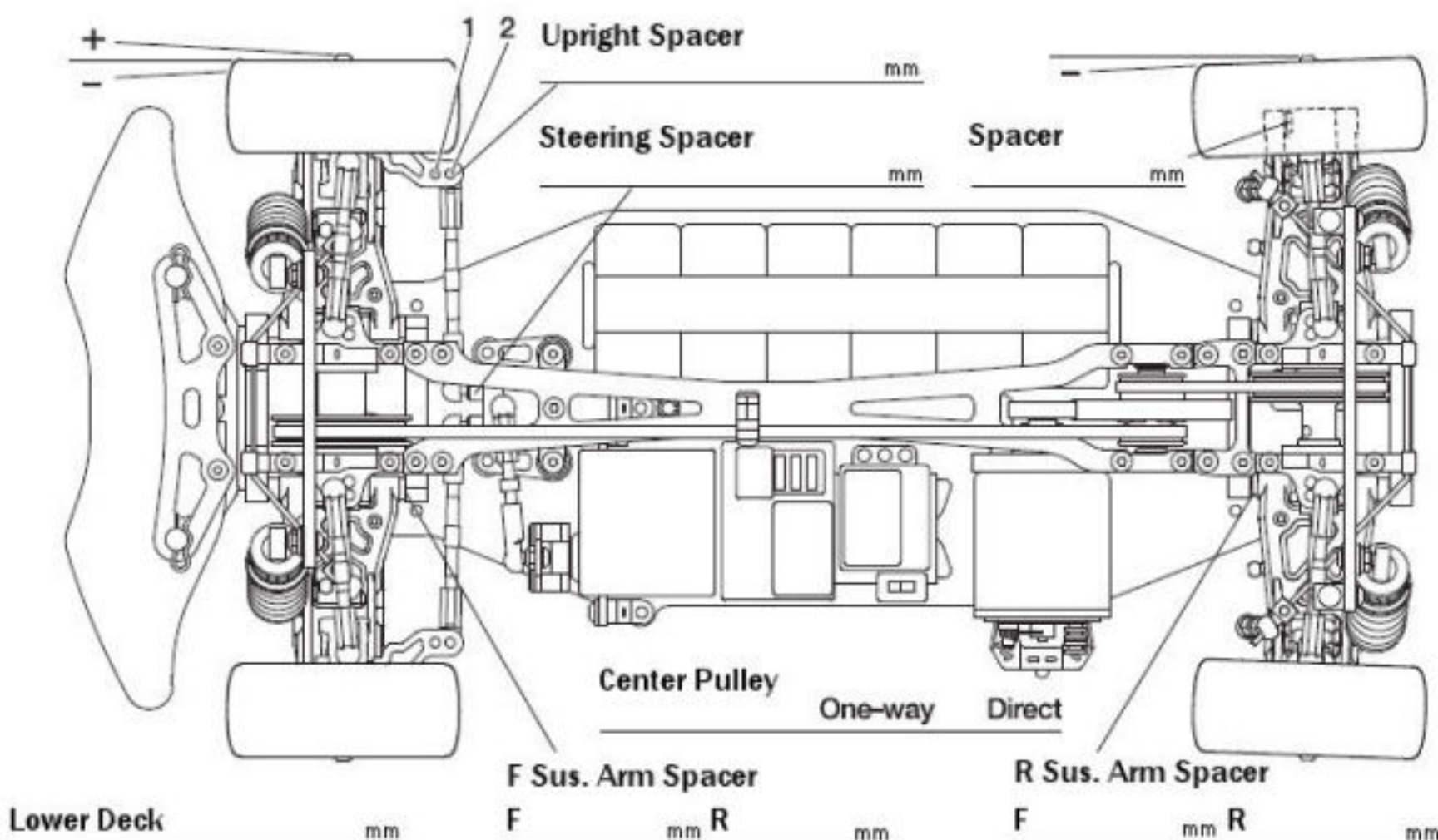

Motor \_\_\_\_\_  
Spur Pinion \_\_\_\_\_  
T T  
Battery \_\_\_\_\_  
Body \_\_\_\_\_  
Wing \_\_\_\_\_  
Tire \_\_\_\_\_  
Wheel \_\_\_\_\_  
Insert \_\_\_\_\_  
Best Lap \_\_\_\_\_