

Transmitter
 Turning Circle: D/R 100%
 Steering Expo: -45
 Brake E.P. : 80
 Throttle Expo: -

Speed Control
 S.C. Type: LRP TC Spec
 S.C. Settings: 2.4.0.1

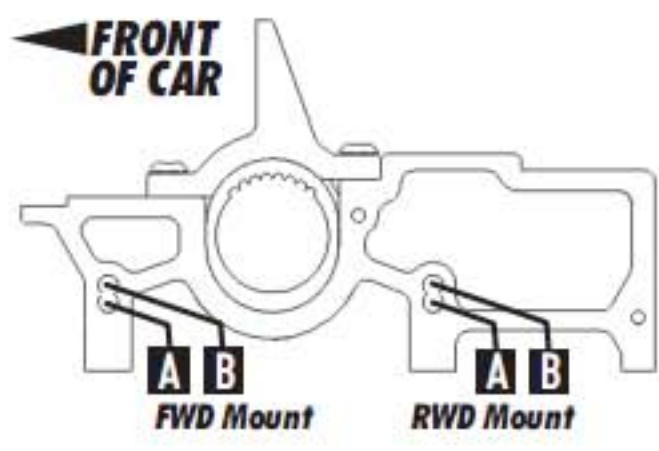

Front	Alignment	Rear
4.25mm	Ride Height	4.5mm
-2.0°	Camber	-3.0°
6°	Caster	N/A
N/A	Rear Hub Toe	1°
0,5°	Toe (Total)	-3.0°
0.5mm	Hex Spacing	0.5mm
2mm	Wheelbase	2mm
2B	Steering Link	N/A
silver 3mm	Bumpsteer	N/A

Notes:

Suspension Geometry		
2B	Shock Position	2B
3	Camber Link Position	5B
silver + 0mm	Outer Ball & Shims	black + 4mm
3A	FWD Arm Mount	2A
2mm	FWD Mount Shims	1mm
3A	RWD Arm Mount	2A
2mm	RWD Mount Shims	3.0mm
1.5mm	Droop	1.5mm
1.25mm	Anti-Roll Bar	-

Notes: All hard Plastic Parts

Shocks		
Asso 70 wt	Oil	Asso 30 wt
# 3 TRF	Piston	# 3 TRF
2mm	Rebound	2mm
copper	Spring	blue

Notes: No rebound Foam

Differentials		
Alum.Diff	Type	Alum.Diff
loose 1/8	Setting	loose 1/8
A	Cam Holder	B
6	Belt Tension Number	15

Notes:

Tires		
pink/orange	Tire	dbl pink
57mm	Tire Diameter	57mm
Jaco Prism	Insert & Wheel	Jaco Prism
Keil 3 / 1/2	Additive & Amount	Keil 3 / full

Notes: Front 15 Min / Rear 40 Min

Chassis		
Chassis: Orig.		
Top Plate: Orig./No Screw in Motor mount		
Notes: F+R Bulkhead cut/		

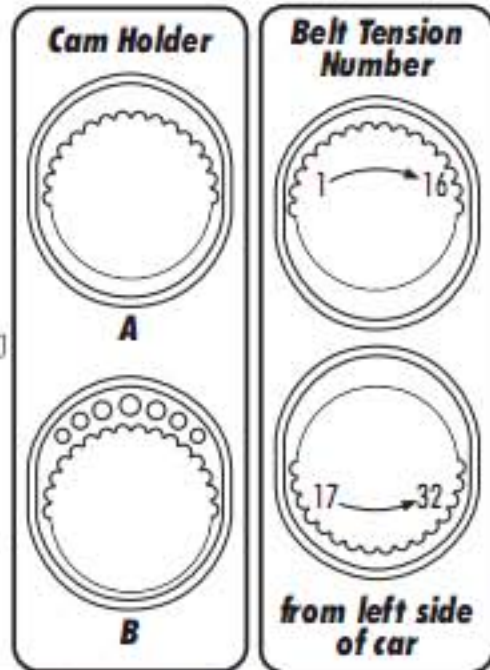
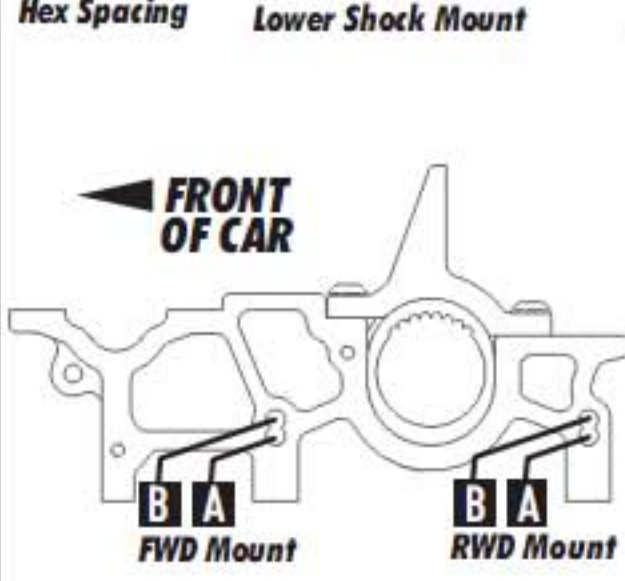
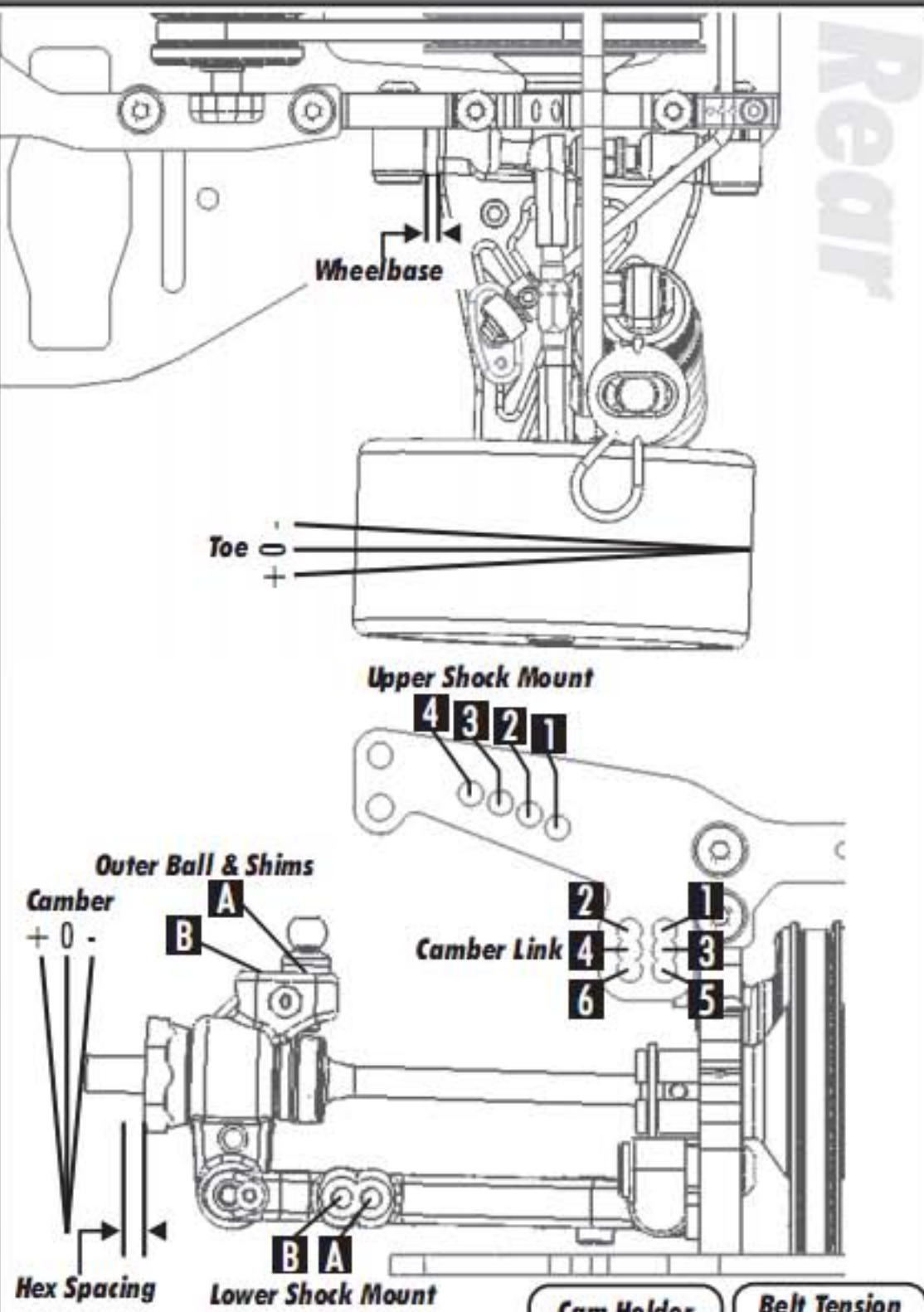

Motor	Gear	Notes
LRP X11 3.5T / 12.5	20 / 87	Timing 3°

Body & Wing
PF R9F/ orig.

Battery
LRP V-Tec 4600 Hv2