

Rear	Alignment	Front
	Ride Height	
	Camber	
N/A	Caster	
	Rear Hub Toe	N/A
	Toe	
	Hex Spacing	
	Wheelbase	
N/A	Steering Link	
N/A	Bumpsteer	

Notes:

Differentials		
	Type	
	Setting	
	Belt Tension Number	
	Cam Holder	

Notes:

Tires		
	Tire	
	Tire Diameter	
	Insert & Wheel	
	Additive & Amount	

Notes:

Shocks		
	Oil	
	Piston	
	Rebound	
	Spring	

Notes:

Chassis		
	Chassis:	
	Top Plate:	

Suspension Geometry		
	Shock Position	
	Camber Link Position	
	Outer Ball & Shims	
	FWD Arm Mount	
	FWD Mount Shims	
	RWD Arm Mount	
	RWD Mount Shims	
	Drop	
	Anti-Roll Bar	

Notes:

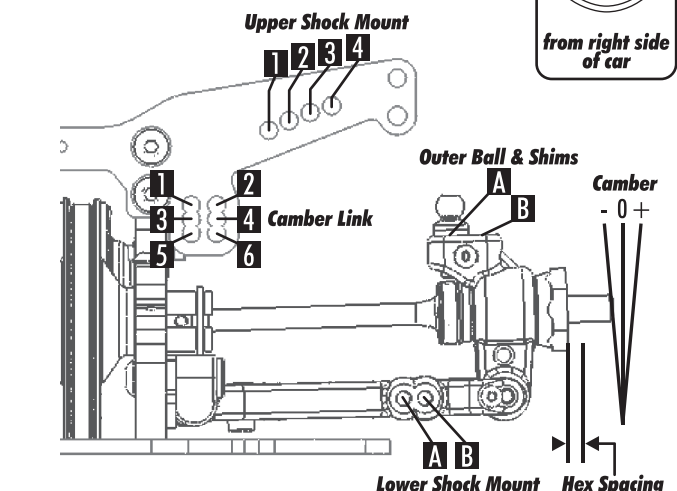
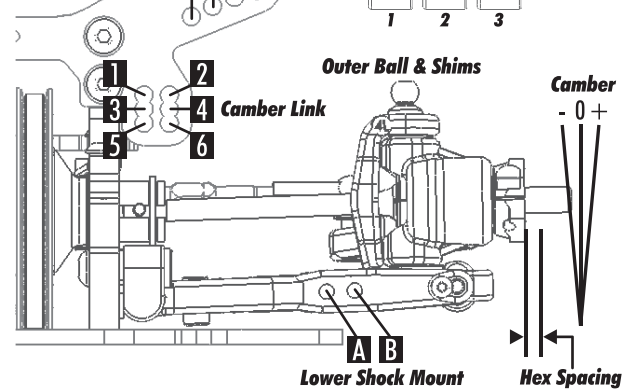
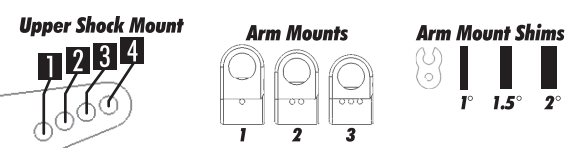
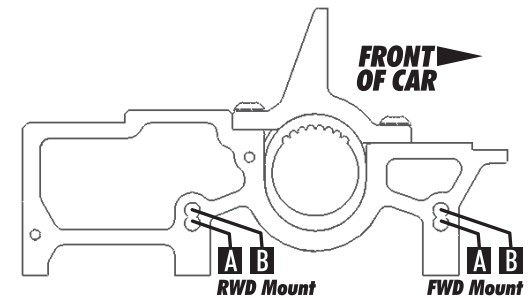
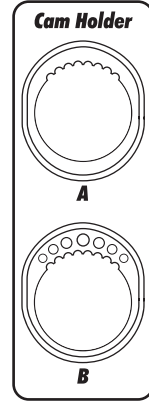
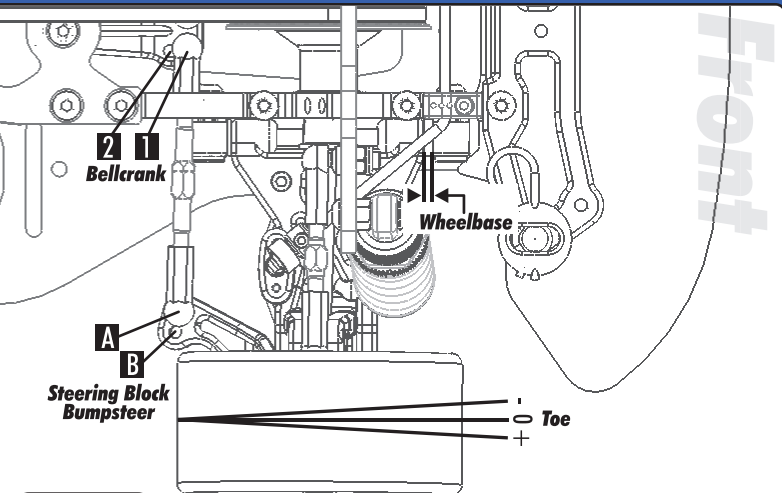

Body & Wing

Battery

Motor **Gear** **Brush** **Spring** **Timing**